

Bolt inspection probes

- Straight beam contact phased array probes
- For the detection of defective areas in threaded bolts
- High quality inspection and probability of detection
- Reduce construction failures and potential liability
- Protective membrane for steady coupling on rough surfaces
- Available with different connectors

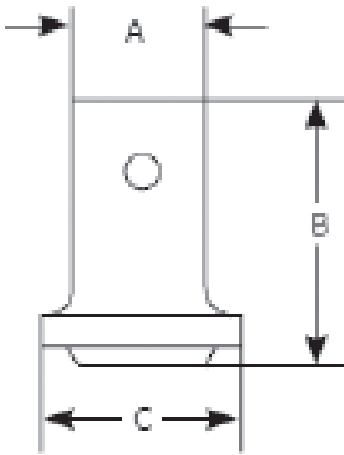

Part Number Phasor	Part Number Mentor	Part Number Hypertronics	Part Number Omnicscan	Probe Description	Frequency (MHz)	Element Count	Pitch (mm)	Elevation (mm)	Cable (m)	Case Style	A (mm)	B (mm)	C (mm)
0069805	0600416	0069894	0069888	B2S PA16	2	16	1.5	24	3	B S	30	59	45
0069806	0600417	0069895	0069889	B4S PA16	4	16	1.5	24	3	B S	30	59	45
0069905	0600418	0069909	0069907	MB2S PA16	2	16	0.63	10	3	MB S	20	43	25
0069906	0600419	0069910	0069908	MB4S PA16	4	16	0.63	10	3	MB S	20	43	25